



Compressor
Voltage Code : FZ

CAJ9480X

High Temp. Commercial (MHP)

220 - 240V 1~ 50 Hz

R134a / R513A / R452A / R404A / R448A / R449A AJK480X-FZ3B

Conditions	Frequency	Nominal Cooling Capacity		Sound Power ISO3745 / ISO 3743-1
		Watts	BTU/h	
EN12900 / R134a	50 Hz	1166	3975	61 dBA
EN12900 / R513A	50 Hz	1180	4024	61 dBA
EN12900 / R452A	50 Hz	1883	6422	61 dBA
EN12900 / R404A	50 Hz	1879	6406	61 dBA
EN12900 / R448A	50 Hz	1885	6428	61 dBA
EN12900 / R449A	50 Hz	1885	6428	61 dBA

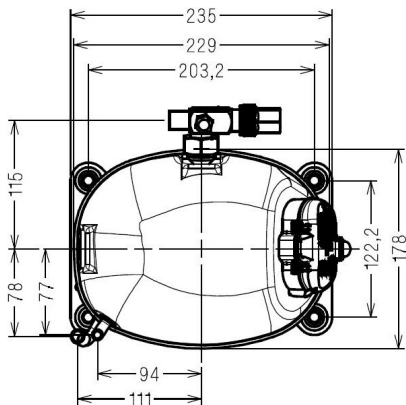
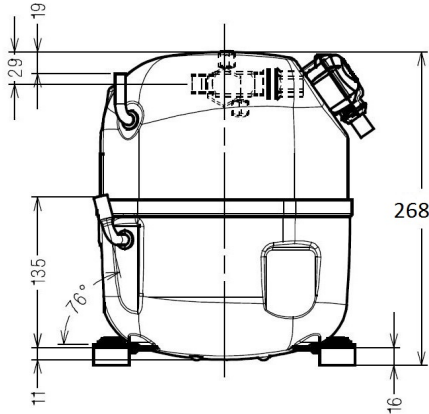

* EN12900 : T°Cond. 50.0°C / T°Evap. 5.0°C / T°Return gas temp.. 20.0°C
T°Subcooling. 0.0K

Certificates :



Displacement (cc)	15.2
Net Weight (Kg)	20.1
Oil Quantity (cc)	475.0
Oil Type	Polyolester
Expansion Device	Capillary_Tube/Expansion_Valve
Cooling	Fan
Main Winding (Ohm)	3.7
Start Winding (Ohm)	12.5
Current	
RLA (A)	4.3
MCC (A)	6.8
LRA (A)	24.1
Electrical Equipment	CSR
Overload	MST22ALK
Time Check	7.5s - 14s / 15.3 A
Open Temp	105° C
Close Temp	61° C
Optional	T0155
Start Capacitor	88 µF / 250 V
Run Capacitor	15 µF / 400 V
Potential Relay	RVA4I**
Pick Up	204/233V
Drop Out	50/110V
Optional	3ARR3*6AU*
Refrigerating connection for OD	
Suction Tube	12.7 (1/2")
Discharge Tube	7.9 (5/16")
Process Tube	6.35 (1/4")

Note : Tecumseh reserves the right to change information contained in this document without notification.



Tecumseh

CAJ9480X	Tension FZ : 220 - 240V 1~ 50 Hz
-----------------	---

Les performances sont données dans les **conditions EN12900** :
 Condition Dew
 The performance data are in **EN12900 conditions** :
 Dew Condition

Gaz aspirés : 20.0 °C
 Sous refroidissement : 0.0 K
 Return gas : 20.0 °C
 Subcooling : 0.0 K

© 2018 Tecumseh Products Company
All rights reserved

50 Hz R134a

N°2470

4 T condensation	5 T évaporation	(°C)	-25	-20	-15	-10	-5	0	5	10	15
40	1 P frigorifique	(Watt)	227	356	503	677	883	1129	1419	1759	2153
	2 P absorbée	(W)	259	308	352	393	429	461	490	515	537
	3 I absorbée	(A)	2.65	2.76	2.86	2.97	3.08	3.19	3.30	3.41	3.53
50	1 P frigorifique	(Watt)		243	378	532	710	919	1166	1454	1789
	2 P absorbée	(W)		288	347	401	450	496	536	573	606
	3 I absorbée	(A)		2.66	2.82	2.98	3.13	3.29	3.45	3.61	3.77
60	1 P frigorifique	(Watt)			241	376	528	703	908	1147	1424
	2 P absorbée	(W)			316	386	451	511	566	617	663
	3 I absorbée	(A)			2.70	2.90	3.11	3.31	3.52	3.73	3.93

50 Hz R513A

N°2383

4 T condensation	5 T évaporation	(°C)	-25	-20	-15	-10	-5	0	5	10	15
40	1 P frigorifique	(Watt)	267	402	554	730	936	1178	1460	1789	2168
	2 P absorbée	(W)	280	332	379	421	459	492	522	549	573
	3 I absorbée	(A)	2.65	2.76	2.86	2.97	3.08	3.19	3.30	3.41	3.53
50	1 P frigorifique	(Watt)		271	411	566	741	944	1180	1454	1769
	2 P absorbée	(W)		305	368	426	478	526	570	610	646
	3 I absorbée	(A)		2.66	2.82	2.98	3.13	3.29	3.45	3.61	3.77
60	1 P frigorifique	(Watt)			254	391	541	709	901	1123	1378
	2 P absorbée	(W)			331	406	476	541	601	656	708
	3 I absorbée	(A)			2.70	2.90	3.11	3.31	3.52	3.73	3.93

1 = cooling capacity 2 = power input 3 = current 4 = condensing temperature 5 = evaporating temperature

Nota : Tecumseh se réserve le droit de modifier les informations contenues dans ce document sans préavis.

Note : Tecumseh reserves the right to change information contained in this document without notification.



Tecumseh

CAJ9480X	Tension FZ : 220 - 240V 1~ 50 Hz
-----------------	---

Les performances sont données dans les conditions EN12900 :	Gaz aspirés :	20.0 °C
Condition Dew	Sous refroidissement :	0.0 K
The performance data are in EN12900 conditions :	Return gas :	20.0 °C
Dew Condition	Subcooling :	0.0 K

50 Hz R452A											
											N°2462
4 T condensation	5 T évaporation	(°C)	-25	-20	-15	-10	-5	0	5	10	15
30	1 P frigorifique	(Watt)	725	941	1200	1508	1870	2294	2785	3350	3996
	2 P absorbée	(W)	458	505	549	587	621	649	670	684	690
	3 I absorbée	(A)	2.24	2.45	2.63	2.79	2.92	3.03	3.11	3.17	3.21
40	1 P frigorifique	(Watt)	570	765	991	1255	1562	1920	2335	2812	3359
	2 P absorbée	(W)	465	526	584	638	687	732	771	803	828
	3 I absorbée	(A)	2.20	2.49	2.76	3.00	3.23	3.42	3.60	3.75	3.87
50	1 P frigorifique	(Watt)		584	778	998	1252	1545	1883	2273	2722
	2 P absorbée	(W)		533	606	677	743	806	864	916	961
	3 I absorbée	(A)		2.48	2.83	3.17	3.48	3.77	4.03	4.27	4.48
60	1 P frigorifique	(Watt)			560	738	938	1166	1429	1733	2084
	2 P absorbée	(W)			614	702	788	870	947	1021	1088
	3 I absorbée	(A)			2.85	3.27	3.67	4.05	4.41	4.74	5.05

50 Hz R404A											
											N°2307
4 T condensation	5 T évaporation	(°C)	-25	-20	-15	-10	-5	0	5	10	15
30	1 P frigorifique	(Watt)	773	992	1254	1563	1925	2346	2833	3391	4025
	2 P absorbée	(W)	485	533	577	616	649	675	695	706	710
	3 I absorbée	(A)	2.37	2.58	2.76	2.92	3.05	3.15	3.23	3.28	3.30
40	1 P frigorifique	(Watt)	609	805	1032	1294	1598	1950	2355	2820	3350
	2 P absorbée	(W)	496	558	616	669	718	762	798	828	850
	3 I absorbée	(A)	2.34	2.64	2.91	3.15	3.37	3.56	3.73	3.86	3.98
50	1 P frigorifique	(Watt)		615	807	1024	1271	1554	1879	2251	2678
	2 P absorbée	(W)		569	642	712	778	839	894	943	986
	3 I absorbée	(A)		2.64	3.00	3.33	3.64	3.92	4.17	4.40	4.60
60	1 P frigorifique	(Watt)			580	752	943	1158	1404	1686	2010
	2 P absorbée	(W)			656	743	827	907	982	1051	1114
	3 I absorbée	(A)			3.04	3.46	3.86	4.22	4.57	4.88	5.17

1 = cooling capacity 2 = power input 3 = current 4 = condensing temperature 5 = evaporating temperature

Nota : Tecumseh se réserve le droit de modifier les informations contenues dans ce document sans préavis.

Note : Tecumseh reserves the right to change information contained in this document without notification.

© 2018 Tecumseh Products Company
All rights reserved



Tecumseh

CAJ9480X	Tension FZ : 220 - 240V 1~ 50 Hz
-----------------	---

Les performances sont données dans les conditions EN12900 :	Gaz aspirés :	20.0 °C
Condition Dew	Sous refroidissement :	0.0 K
The performance data are in EN12900 conditions :	Return gas :	20.0 °C
Dew Condition	Subcooling :	0.0 K

50 Hz R448A (*)											
											N°2915
4 T condensation	5 T évaporation	(°C)	-25	-20	-15	-10	-5	0	5	10	15
30	1 P frigorifique	(Watt)	638	850	1104	1407	1766	2189	2683	3253	3909
	2 P absorbée	(W)	427	470	511	549	582	609	630	644	649
	3 I absorbée	(A)	2.09	2.28	2.45	2.60	2.74	2.85	2.93	2.99	3.02
40	1 P frigorifique	(Watt)		694	918	1182	1492	1856	2280	2772	3339
	2 P absorbée	(W)		494	548	599	647	690	727	757	780
	3 I absorbée	(A)		2.34	2.59	2.82	3.03	3.23	3.39	3.53	3.65
50	1 P frigorifique	(Watt)			732	958	1221	1528	1885	2300	2780
	2 P absorbée	(W)			573	640	705	766	822	873	916
	3 I absorbée	(A)			2.68	3.00	3.30	3.58	3.84	4.07	4.27
60	1 P frigorifique	(Watt)				739	956	1207	1499	1839	2235
	2 P absorbée	(W)				668	753	834	912	985	1052
	3 I absorbée	(A)				3.11	3.51	3.89	4.24	4.57	4.88

50 Hz R449A (*)											
											N°2617
4 T condensation	5 T évaporation	(°C)	-25	-20	-15	-10	-5	0	5	10	15
30	1 P frigorifique	(Watt)	638	850	1104	1407	1766	2189	2683	3253	3909
	2 P absorbée	(W)	427	470	511	549	582	609	630	644	649
	3 I absorbée	(A)	2.09	2.28	2.45	2.60	2.74	2.85	2.93	2.99	3.02
40	1 P frigorifique	(Watt)		694	918	1182	1492	1856	2280	2772	3339
	2 P absorbée	(W)		494	548	599	647	690	727	757	780
	3 I absorbée	(A)		2.34	2.59	2.82	3.03	3.23	3.39	3.53	3.65
50	1 P frigorifique	(Watt)			732	958	1221	1528	1885	2300	2780
	2 P absorbée	(W)			573	640	705	766	822	873	916
	3 I absorbée	(A)			2.68	3.00	3.30	3.58	3.84	4.07	4.27
60	1 P frigorifique	(Watt)				739	956	1207	1499	1839	2235
	2 P absorbée	(W)				668	753	834	912	985	1052
	3 I absorbée	(A)				3.11	3.51	3.89	4.24	4.57	4.88

1 = cooling capacity 2 = power input 3 = current 4 = condensing temperature 5 = evaporating temperature

(*) Veuillez vous référer strictement aux Recommandations d'Utilisation et Bulletins Marketing Tecumseh du fait de la température de reflux élevée pour les applications LBP.
 (*) Due to very high discharge temperature especially on LBP conditions, please strictly refer to Tecumseh Guidelines & Marketing Bulletin when using this refrigerant.

Nota : Tecumseh se réserve le droit de modifier les informations contenues dans ce document sans préavis.

Note : Tecumseh reserves the right to change information contained in this document without notification.

© 2018 Tecumseh Products Company
All rights reserved